



IndiGo NIR

Handheld modular spectrometer

About Goyalab

Goyalab is a French start-up that designs, develops and markets measurement tools based on spectrometry. Moreover, it provides expertise in Research and Development, serving the industry in the development of specific applications in spectrometry.

Goyalab's philosophy is to develop powerful spectrometry tools that are easy to use, mobile and affordable thanks to new communication technologies (smartphones, tablets).

Goyalab wants to democratize spectrometry and make it accessible to all.



With IndiGo, the power of spectroscopy is at your fingertips

IndiGo NIR is a modular handheld near Infra-Red spectrometer. This new spectrometer allows the user to measure emission, absorption or transmission spectra directly on a smartphone or a PC. The wavelength range goes from 700 nm up to 1050 nm with a typical resolution below 2 nm.

IndiGo NIR provides data compatible with all the chemiometric softwares (R, Solo, Unscrambler et Quasar). Customisation of the firmware to associate your chemiometrics model is possible.

LEDs excitation module are designed to ensure a perfect stability of excitation over the time.

With its optional modules, IndiGo NIR can allow analyses on liquid or on solid samples.



Features

- > Modular spectrometer
- > Bluetooth connectivity
- > Battery or mains powered
- > CE & TELEC certifications (FCC on-going)
- > Plug-n-Play Interface for PC applications
- > Free PC software

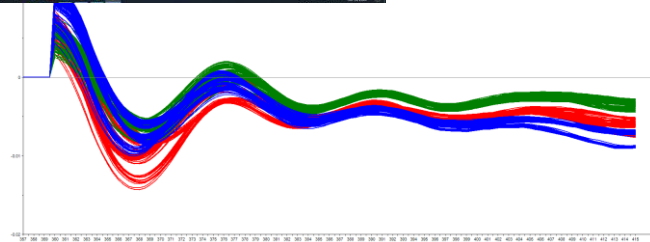
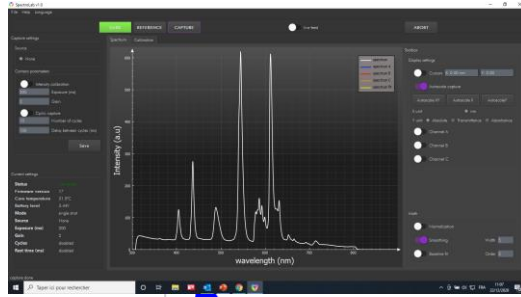

Optional modules



LED EXCITATION MODULE

The LED ring module allows the user to add a continuous Infra-Red light source (from 700nm up to 1050nm) to the IndiGo for reflection measurements.

The LED ring is covered by a sapphire window to ensure the protection of the electronics while ensuring the transparency over the NIR region.

The design allows to take measurements of protein, fat or quantity of water without being polluted by the environment light.

LASER MODULE

This module includes a laser excitation source at 780nm a set of filters to perform Raman measurements.

The module contains a RMS thread to adapt microscope objective at the top.



CUVETTE HOLDER MODULE

This module allows the user to measure spectra in liquids thanks to its cuvette holder. This module contains a ring of IR LEDs protected by a sapphire window.

This module is very useful to measure the humidity, the quantity of fat or sugar and protein.



Specifications

<i>PHYSICAL</i>	
Dimension	76 x 45 x 53 mm
Weight	107g

<i>SPECTROMETER</i>	
Sensor	4.2 Mpx Sony CMOS Rolling Shutter sensor Dim: 2712 x 1538 – pixel size: 2.9µm
Wavelength Range	700-1050 nm
Spectral Resolution	<2nm (FWHM)
Slit (W x H)	25 µm x 3 mm
Grating	600 Lines/mm
Integration Time Range	1ms - 24s (multi cycles acquisition available)

SYSTEME CONFIGURATIONS

Battery	10h in operation & 24h in standby mode
Data Format	.txt – CVS - spc
Power	5V - 750mA

ENVIRONMENTAL CONDITIONS

Temperature	0°C - 30°C operation & -10°C - 40°C Stockage
Humidity	0% - 90% noncondensing

INTERFACES

Bluetooth	5.0 Bluetooth Low Energy
USB	USB-C
Software	SpectroLab software (including Python interface) SpectroLab Expert (Goyalab Chemiometric software) Files compatible with KnowItAll, CrystalSleuth

CALIBRATION

Wavelength	Made in factory with Hg / Ar low pressure lamp
Intensity	Available in option

► Dimensions

Core module

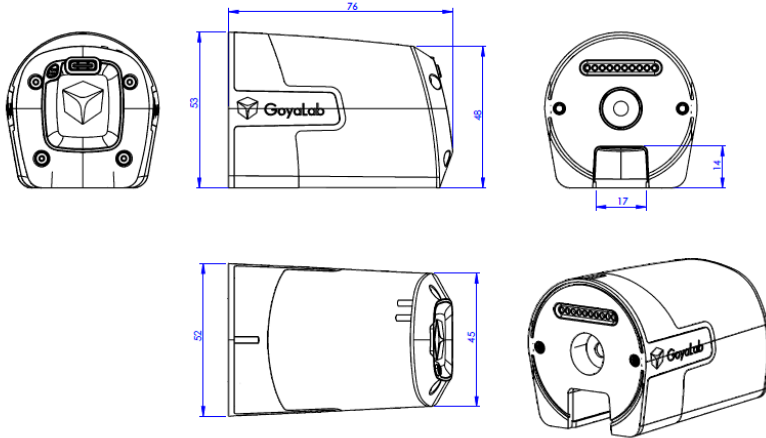

Laser module

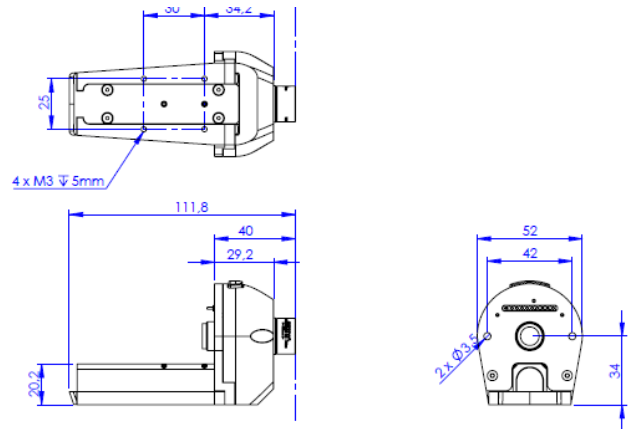

Cuvette holder module

